

F762..C High Current Probe for Blade Connectors



Center: 4,00mm/157 mil | Current I_{eff} : 40,0 A | Temperature: -40...+250°C | R_{typ} : < 5,0 mOhm

The twist proof probe F762 is designed for contacting flat blade connectors in high current applications.

Mechanical Specifications

- Nominal travel: 4,00 mm
- Maximum travel: 5,00 mm
- Preload: 70 cN
- Nominal force: 300 cN



Materials and Plating

- Barrel: Brass, gold plated
- Plunger: BeCu, gold plated
- Spring: Stainless steel, unplated
- Receptacle: BeCu, gold plated

Temperature Characteristic

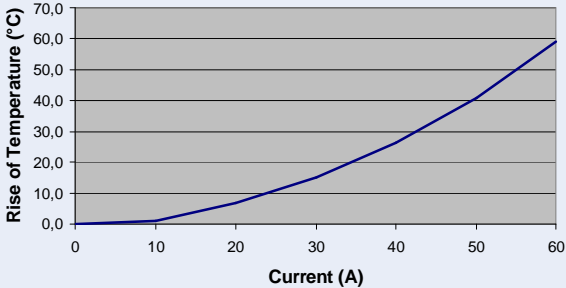

Order code: F76289B0001G300C

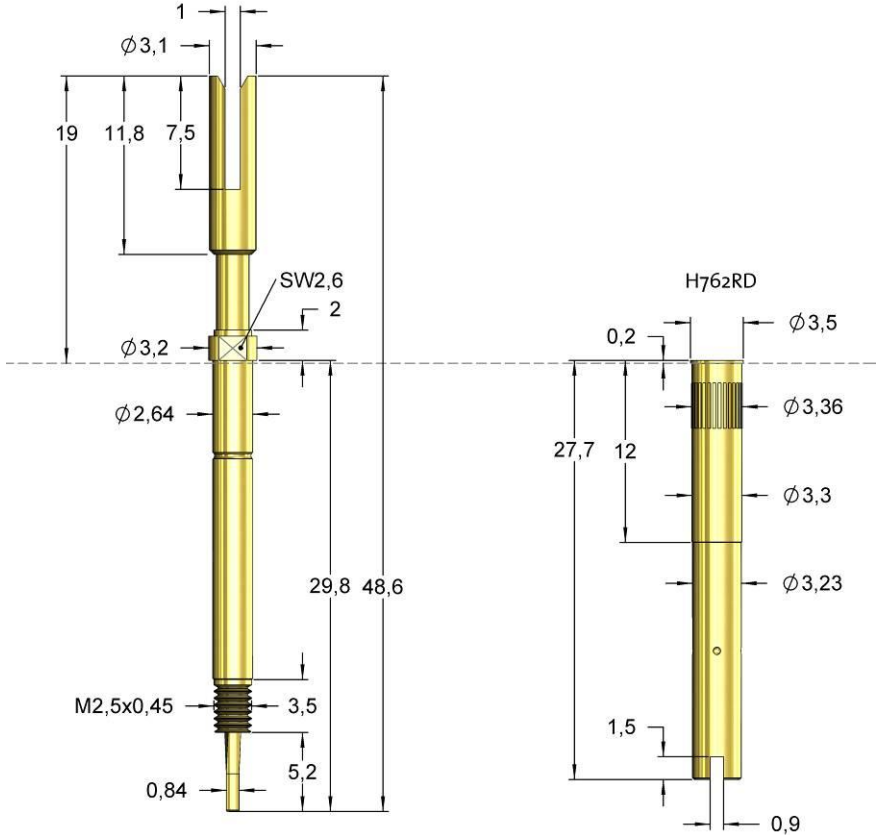

F762..C High Current Probe for Blade Connectors



Center: 4,00mm/157 mil

Current I_{eff} : 40,0 A

Temperature: -40...+250°C

R_{typ} : < 5,0 mOhm

Functional principle

Due to the twist proof design the plunger is always brought to the test item well aligned. Once the plunger is compressed by contacting the blade connector, it is twisted up to a maximum of 30°. This results in a good electrical contact without damaging or scratching the tested item.

Important: The probe needs to be moved axially to the blade connector. A chamfer at the contact probe enables an optimum guiding.

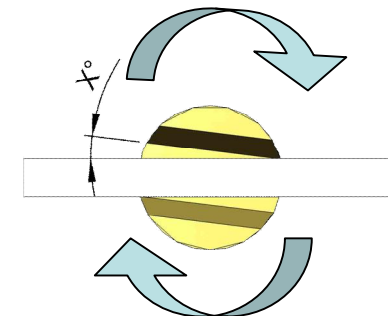
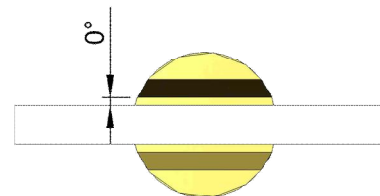
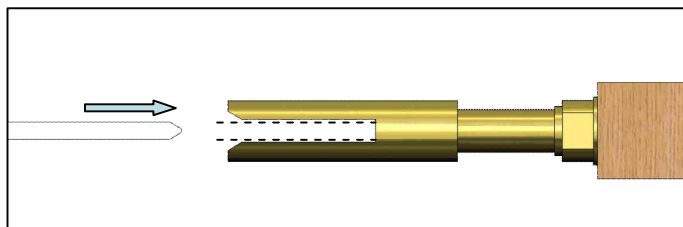
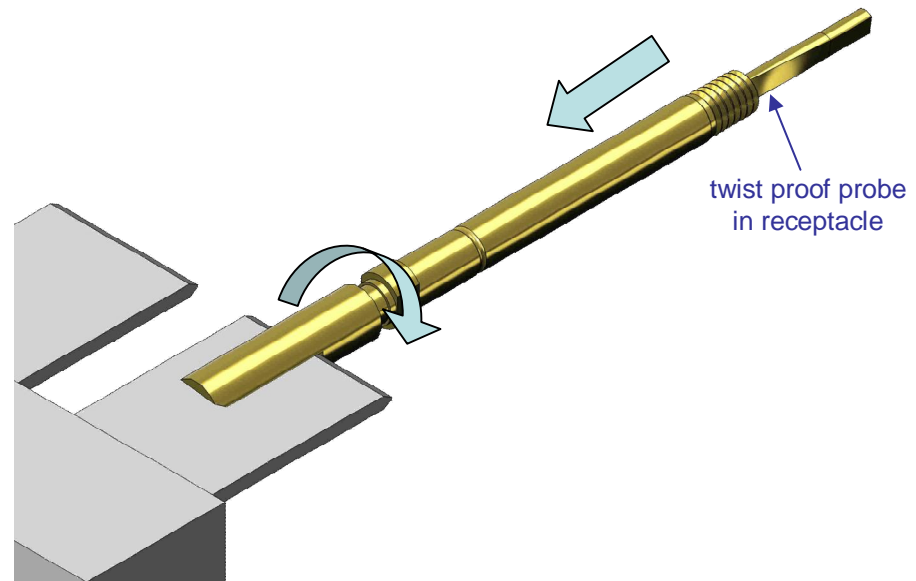

F762..C High Current Probe for Blade Connectors



Center: 4,00mm/157 mil

Current I_{eff} : 40,0 A

Temperature: -40...+250°C

R_{typ} : < 5,0 mOhm

Application note

Higher currents can be realized by using several probes in parallel, e.g. 120 A in this example.

In applications with Kelvin tests a normal spring contact probe can be used for the voltage (sense signal).

